

# SERIES SPIDER 13.80

## Compact, easy and lightweight for every use

- Unrivalled stability at high altitude
- Ultra-compact stabilization and zero tail gate
- Agile and stable on a variable width crawler tracks
- Easy maintenance
- Simple and intuitive on-board equipment
- Ultra-light and easy to transport
- Standard with double drive speed

- Fully protected by metal covers against falling objects
- Air/water and 230Vac outlets are available into the basket
- Supplied with counter-weight to increase the side outreach
- Quick detach and interchangeable basket

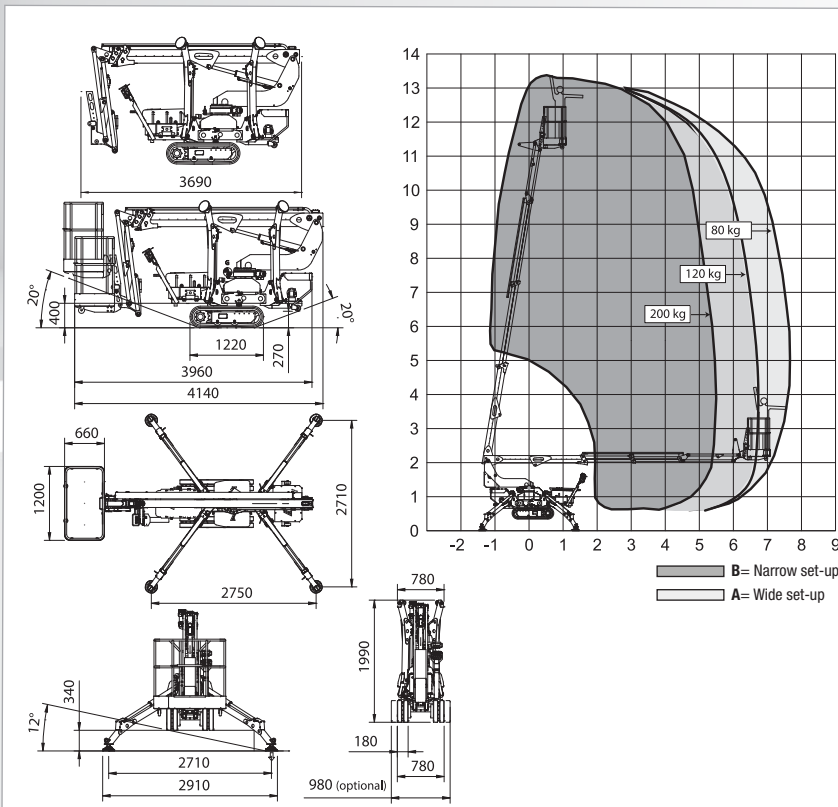

TECHNICAL SPECIFICATIONS		STD	E	ED
Maximum working height	m		13,40	
Floor height	m		11,40	
Maximum side outreach	m		7,80	
Rotation angle of the tower	°		360	
Aluminium basket dimensions	m		1,20 x 0,70	
Basket rotation angle	°		ND	
Maximum capacity of basket	Kg		200	
Length closed (basket disassembled)	m		3,55 (4,20)	
Minimum width closed	m		0,78	
Minimum height closed	m		1,98	
Overall dimensions Stabilization	m		2,80 X 2,80	
Maximum horizontal inclination	degrees/%		16° (29%)	
Maximum side inclination	degrees/%		12° (21%)	
Maximum speed	Km/h	3,50	1,70	3,50
WEIGHTS		STD	E	ED
Weight in work conditions*	Kg	1500*	1500*	1650*
Ground pressure stowed machine	KN/m <sup>2</sup>		3,06	
Ground pressure when on stabilizers	KN/m <sup>2</sup>		2,26	
Max point load on one stabilizer	KN		11,8	
POWER		STD	E	ED
Honda GX270 petrol engine	HP/rpm	8/3600	-	-
1B30 HATZ diesel engine	HP/rpm	7,2/3600	-	5,4/3600
Electric motor 220 Vac	CV/KW	3 / 2,2	3 / 2,2	-
Electric Motor 24 Vdc	CV/KW	-	5,5/4,0	5,5/4,0
Traction battery capacity	24Vdc Lead Acid 24Vdc Lithium Ion	Ah	- 150 200	- 150 200
Battery charger	lead acid lithium ion	Ah	- 45 100/50	- 45 100/50

\* Subject to change depending on configuration.